

Utility Distribution System (UDS)



710 S. Powerline Road Suite H
Deerfield Beach, FL 33442
(954) 570-9860 (800) 322-8730 FAX(954) 570-9865
www.hooddepot.net

DISTRIBUTOR SHIPPING

In order to move the Distributor System into the building, it may be broken down into several sections before shipping. Normally, the break points are at the intersection of the horizontal raceway and the vertical riser or where two or more sections of raceway meet. Gas hoses and cord & plug sets are shipped in separate boxes and should be stored safely until after the Distributor System has been assembled and set into place. Before uncrating the Distributor, check the packing list to make sure that all of the crates and boxes have arrived. Move the crates into the kitchen area to a location as near as possible to its destination to minimize the risk of moving damage.

Next, uncrate the Distributor being especially careful with tools that could scratch or dent the stainless steel finish. The system and all of its components should be thoroughly inspected for shipping damage. If any damage is found, it should be specifically noted on the shippers paperwork and the factory should be notified immediately.

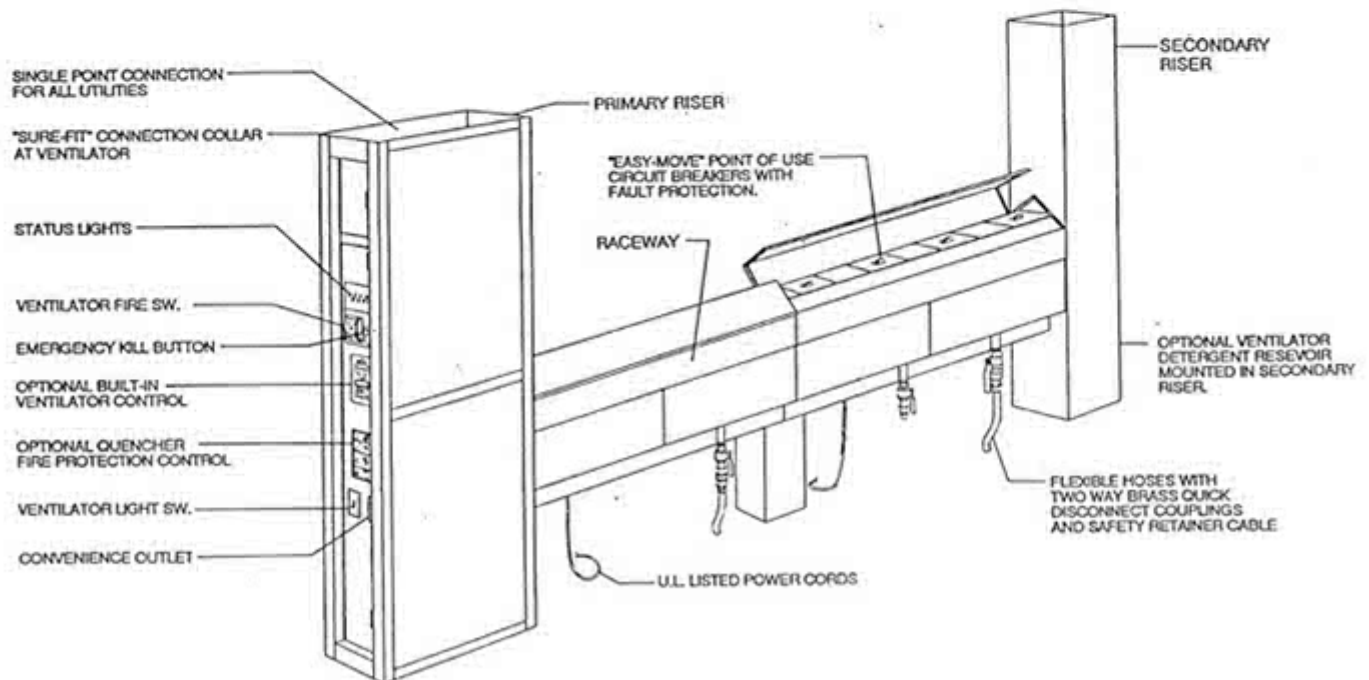

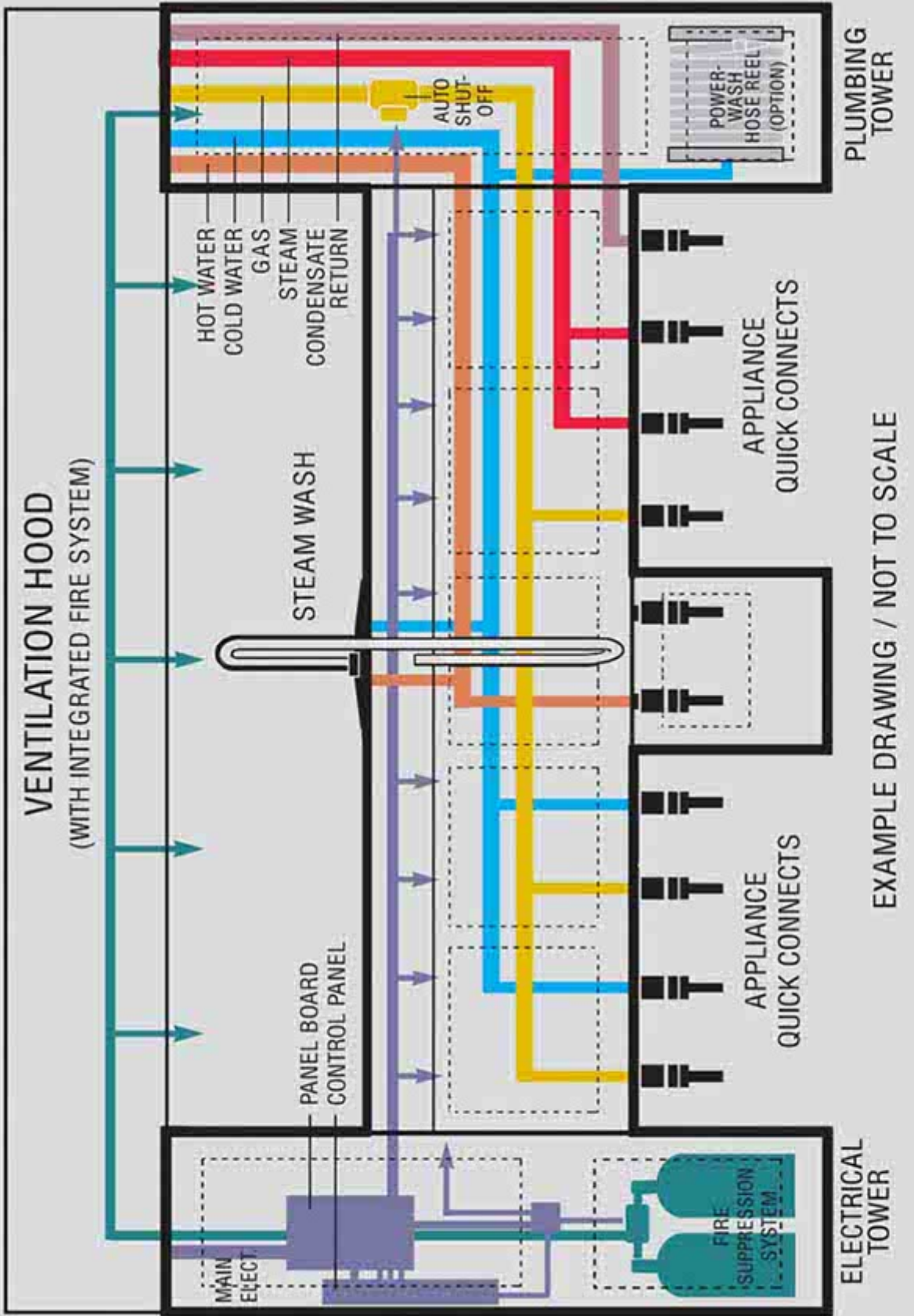

Configurations: Systems may be Wall Style, Island or Overhead. Electrical service available in Bus Bar type or Conventional Panel. Piping Service typically include Gas, Hot Water, Cold Water, Steam and Condensate/Return as needed, with many other custom features available.

Custom Application: Every combination of kitchen size and appliance requirements can be handled by our modular systems. We provide custom engineered plans tailored to each individual project --and meet or exceed regulatory requirements of all governing bodies having jurisdiction.

DISTRIBUTOR ASSEMBLY

HOUSING

The Distributor System can be assembled prior to being moved into place or each section can be set into place while assembling the unit. Assembling the unit in place is preferred since it eliminates the need for moving the entire system in one piece (See Figure 1).

Start by positioning the secondary (smaller) riser next to the open end of the corresponding "Sure-Fit" collar. Remove the collar end cap and slide the riser horizontally into place. Replace the collar end cap and fasten down with the screws provided (See Figure 2).

Position the raceway under the ventilator guiding the pipes and wiring conduit into the holes provided in the riser (See Figure 3). Line up the six bolt holes. Using the nuts, bolts and lock-washers provided, securely fasten the end of the raceway to the riser. The other end should be propped up so that the raceway is level during this procedure (See Figure 4).

Carefully slide the main riser into its corresponding "Sure-Fit" collar while again guiding the gas, water and steam pipes into the opening provided. Line up the bolt holes and securely fasten the raceway to the main riser using the mounting hardware provided. Secure all pedestals and risers to the floor using anchor fittings.

ELECTRICAL

Hood Depot has provided all the necessary wiring between the main riser and the electrical raceway. If the unit was shipped broken down, the main power wires must be reconnected to the bus bars using the color coded terminal lugs provided. The connection point is under the breaker plate located nearest to the main riser. Also at this location is the multi-wire connection plug which is used for the various status lights and other controls. Line up the red terminals on each half and press them together.

Similar connections are required at each intersection along raceways that exceed 15 feet in length excluding the risers. The convenience receptacle located on the opposite riser must also be connected using the pre-wired flexible conduit provided inside the riser (See Figure 4).

PLUMBING

Each intersection along the raceway is provided with unions on the water, gas and steam pipes. Each union must be located and securely tightened down prior to connecting the main utilities to the Distributor. This is required even on units that are shipped in one piece as some loosening is expected during shipment. Test the entire system for leaks before moving on to the next step.

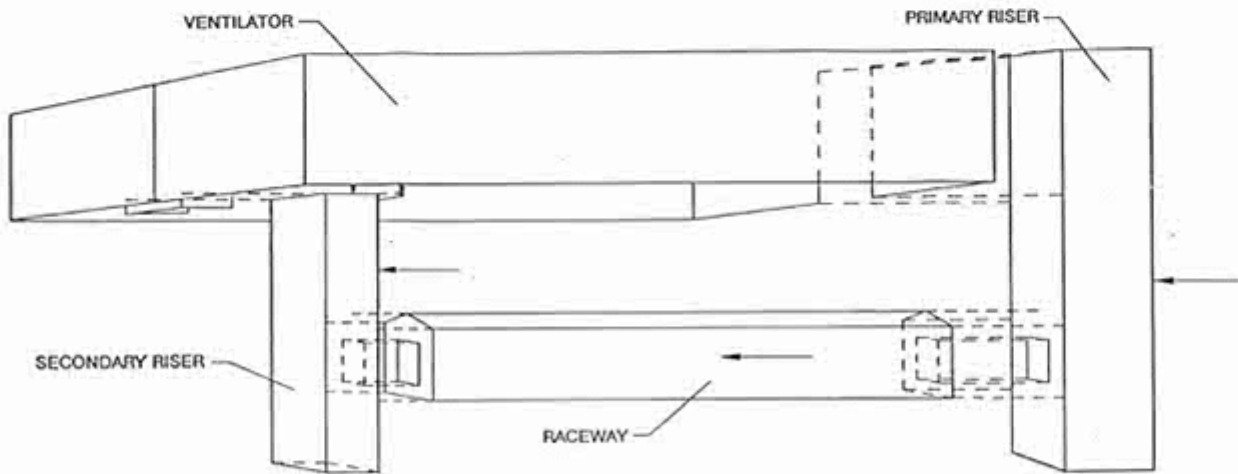

FIGURE 1

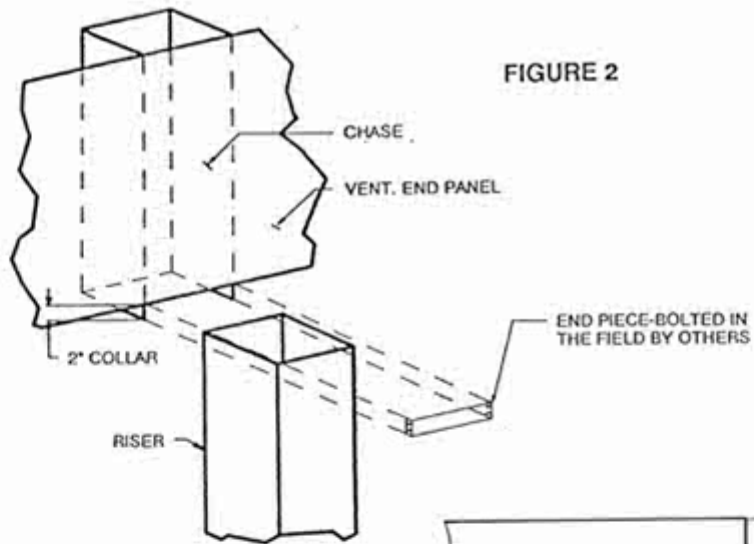

FIGURE 2

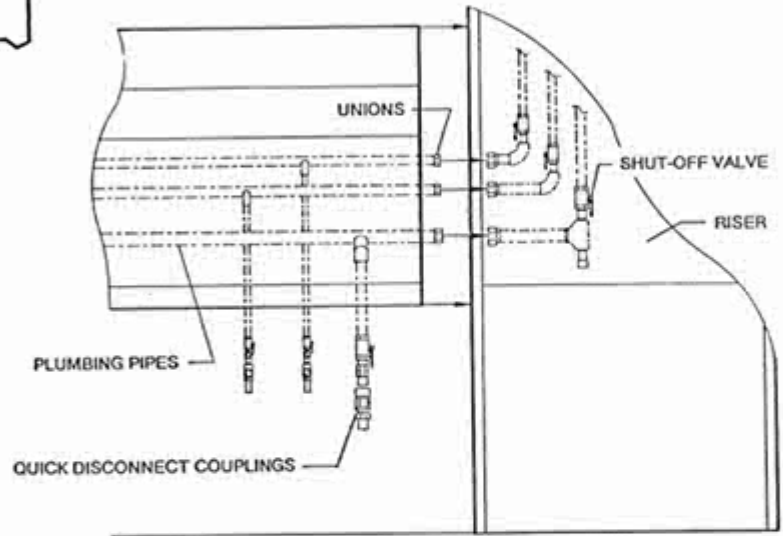

FIGURE 3

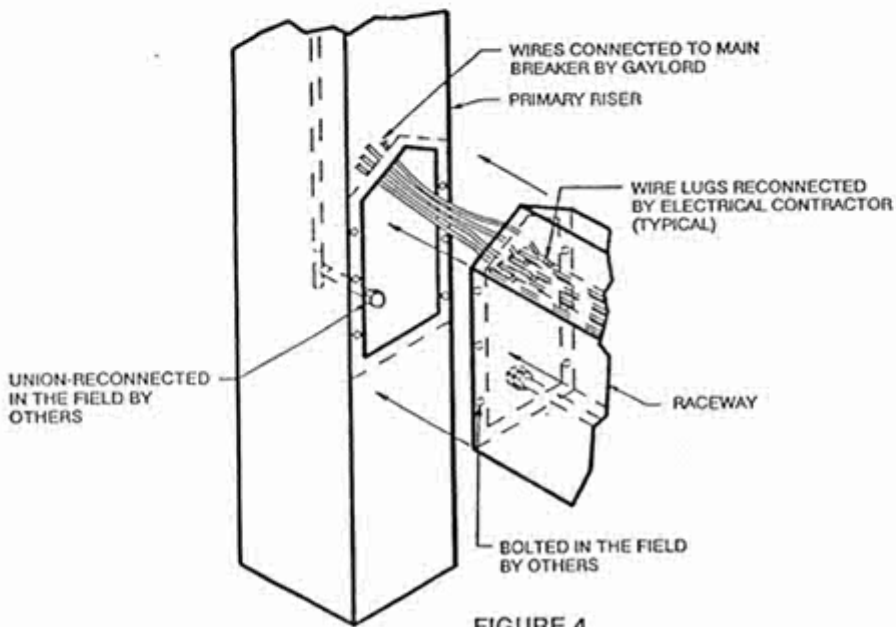

FIGURE 4

FIELD UTILITY CONNECTIONS

All gas, water and steam hoses have been provided by Hood Depot. Each hose must be connected to its intended appliance by the threaded end. The quick-disconnect end can then be plugged directly into the Distributor System.

Each hose assembly must be protected with a restraining device designed to prevent undue tension if the appliance is forcefully pulled away from the Distributor. Connect each cable with one end attached to the ring at the bottom of the Distributor and the other end to the appliance.

VENTILATOR DRAIN INSTALLATION

All water-wash ventilators require a field interconnection between the ventilator drain stub-out and the verticle drain located normally in the secondary riser. To begin, open all access doors at the riser and the bottom side of ventilator. Both connections are located at the inside top portion of the riser. Install appropriate fittings and pipe as required to make the connection between the riser and ventilator. Drain pipe may need to be extended to direct waste into floor sink. Drain installation must comply with all local plumbing codes such as air gap requirement, etc.

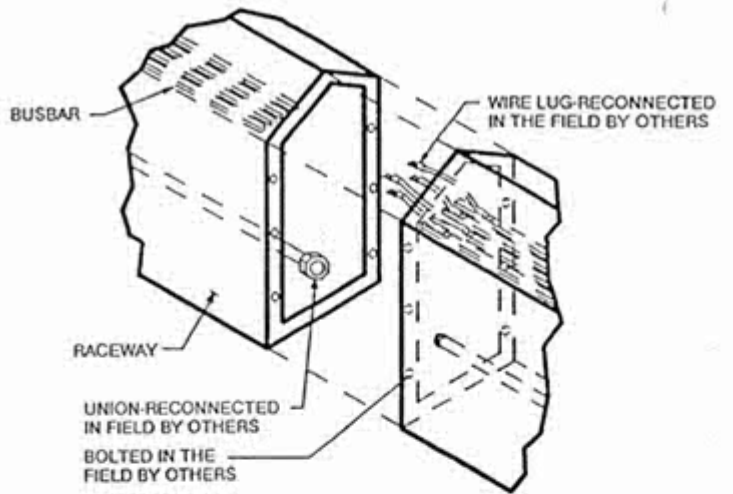

FIGURE 6

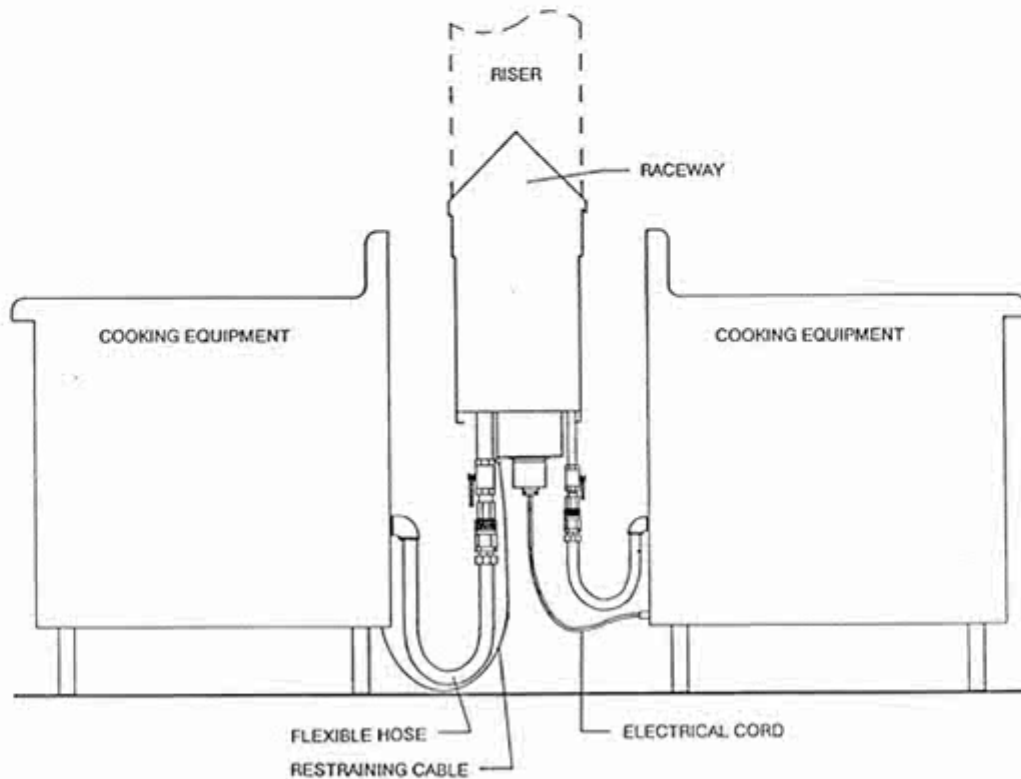

FIGURE 7

FIELD UTILITY CONNECTIONS

The Distributor System is now ready for the field connections. Always begin with the plumbing connections as they provide a natural safety ground for the electrical connections which can be made last.

PLUMBING

Review the layout drawings to become familiar with the location of each plumbing connection point.

The hot water, cold water, steam supply and condensate return pipes are simply connected at a single point in their respective riser and at field joints for multiple sections. Due to the larger size of steam piping, the steam shut-off valve may be shipped loose for field installation. Check all boxes and crates for these and other various fittings such as PRV valves, steam traps and shut-off valves which need to be installed in the field.

The gas piping is often looped through the raceway and requires a connection inside each riser and at field joints for multiple sections. Tighten each fitting and pressure test before start-up. Check the layout drawings to confirm the connection points.

If water-wash controls are mounted in the main riser, a water pipe is required from the outlet located in the riser to the inlet on top of the ventilator.

The Distributor may also be fitted with a Hood Depot Fire Protection System. This will require an inlet connection from the main building sprinkler water pipe and outlet connection running from the riser to the top of the ventilator.

MAIN RISER ELECTRICAL

The main electrical service must be brought in through the conduit knock-out located on the top or bottom of the main electrical riser as shown on the layout drawings (See Figure 5). The hot wires are to be connected directly to the main breaker or terminal blocks marked accordingly. The neutral wire is to be connected to the appropriate terminal block. A green grounding lug is also provided for a field ground wire.

Power for the ventilator light switch is provided from a breaker located in the main electrical riser. This circuit is pre-wired to J-box F in the electrical riser for field connection as shown on the layout drawings. Field wiring is required from this J-box to the ventilator J-box located on top of the ventilator.

If the Distributor System includes an integral water-wash control system or integral fan/off switch, it will require field control wiring from J-box F to the ventilator J-box on top of the ventilator which is for the damper switching circuit. Field wiring is also required from J-box G to the fan motor starters. Read the "Water-Wash" Technical manual thoroughly and make all wiring connections as instructed.

The Distributor System will include terminal connections in J-box G for field wiring to the Ansul micro switch or remote control panel when specified for fire/fuel shutoff.

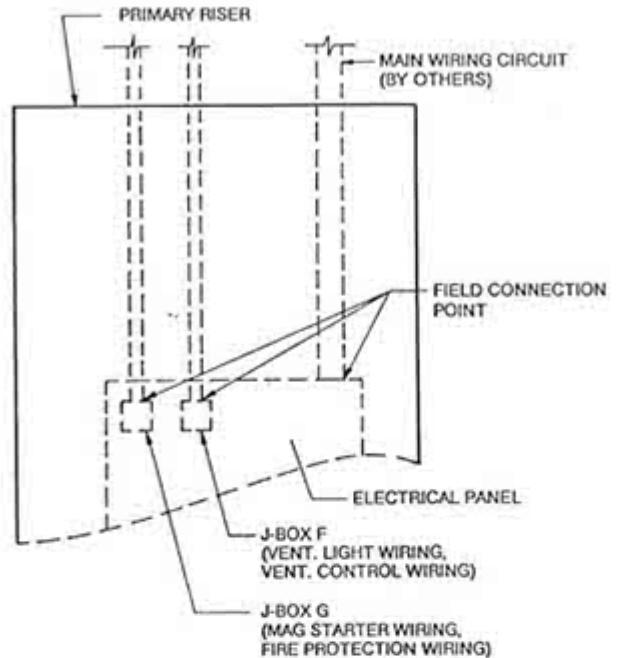

MAIN RISER ELECTRICAL
(SIDE VIEW)
FIGURE 5

RACEWAY ELECTRICAL

Standard with all units are field wiring reconnection points for main busbar and control circuiting. All reconnection points are located at the top of the raceway behind hinged access doors and are clearly marked. Make sure to properly secure wire lugs to busbar for proper electrical connection (See Figure 6). Refer to the layout drawing for field connection points.

COOKING EQUIPMENT

Each appliance can now be moved into place and connected to the Distributor System (See Figure 6). The electrical receptacles are located on the bottom of the raceway on 10" plates. Each receptacle is connected to a dedicated circuit breaker located on a corresponding 10" plate on top of the raceway under the hinged access door. If unsure about which receptacle to use for each appliance, check the label at the circuit breaker for the connection number. All connection numbers are listed in conjunction with the status lights located at the main electrical riser to monitor receptacle/breaker operation. Hood Depot has provided cord and plug sets for appliances which do not come with one installed by the manufacturer. Each cord/plug set provided is tagged with a description of the equipment for which it was intended.

DISTRIBUTOR START-UP AND CHECK-OUT

1. Before proceeding, make sure that all electrical and plumbing connections at the risers and field joints are secure.
2. Turn off all cooking equipment and make sure that the main circuit breaker and each branch circuit breaker is off.
3. Turn on the power feeding the main circuit breaker and check the voltage at the input side of the breaker making sure all three legs have the proper voltage. Turn on the main circuit breaker and the smaller breakers located inside the main electrical panel. The small breakers operate the controls, ventilator lights and convenience receptacles.
4. Close all UDS plumbing branch service valves. Open all main service valves and pressure test each line to assure against leaks. **Note:** If equipped with Ansul fire protection for use with gas service, wiring between the Ansul controls and the UDS gas valve should be done to open valve. If not, test down stream of valve. The gas line may also need to be bled to remove air before operating the equipment.
5. Locate all hoses and cord/plug sets and make the appropriate connections at the equipment and UDS. Now open all branch service valves and turn on each branch circuit breaker.
6. Turn on each piece of equipment and check that it is operating properly.
7. Follow all start-up and check-out procedures as outlined in the appropriate Hood Depot Ventilator Technical Manual(s)

ADDING AND RELOCATING CONNECTIONS

Before making any changes:

- A. Shut off all cooking equipment.
- B. Shut off main circuit breaker.
- C. Close all hand valves providing plumbing services to the raceway.

I. Relocating an electrical branch circuit breaker:

- A. With the main circuit breaker in the off position, lift the support and breaker plate assembly to be relocated out exposing the electrical raceway and busbar.
- B. Disconnect the wires from the busbar and the wire that goes to the wire duct (status light) leaving the load wires attached to the breaker as they run down to the receptacle.
- C. Directly below at the bottom of the raceway, remove the receptacle assembly and disconnect the wires from the receptacle.
- D. The breaker will now lift out from the top with the wires still attached.
- E. Select a new location for this connection from the available blank receptacle plates. Remove the plates from both the top and bottom of the raceway.
- F. Reinstall the breaker by first locating the busbar. You will need to drill and tap the busbar or use strong self-tapping screws which can be used with correctly drilled pilot holes. **Note:** Phase locate the taps as the prior location. **Caution:** Keep a minimum 1" clearance between tap locations.
- G. Now bolt wires from breaker to busbar. **Note:** Extend status light wire in wire duct and reconnect to breaker assembly.
- H. Route wires from the load side of the breaker down through the vertical electrical chase and reconnect the receptacle plate.
- I. Reinstall the blank plates in the spaces previously occupied by the newly relocated breaker/receptacle combination.

II. Adding electrical connections:

Hood Depot will provide additional breaker/receptacle assemblies at a nominal cost given this following critical information:

- A. Job name and serial number of Distributor System.
- B. Electrical characteristics of equipment being added (voltage, phase, amps. K.W., H.P.).
- C. Requirement for special features such as GFI protection, status light, cord and plug set, etc.
- D. Type of receptacle (straight blade, pin and sleeve, conduit with wire pigtails)

You will receive all of the necessary components, mounting hardware and installation instructions including recommendations of which bus bar(s) to use for proper load balance. Refer to relocating branch breaker for installation procedure.

III. Adding Plumbing Connections

When adding or relocating equipment that uses gas, water or steam, a new plumbing connection can be added by removing the inspection door adjacent to the new location and installing a branch pipe to the desired utility main. With the factory installed shut-off valves and fully accessible plumbing compartments, a licensed plumber can easily perform this task without harming the walls, floor or ceiling in the kitchen. Special fittings and hoses can be provided by Hood Depot if needed.

TROUBLESHOOTING

PROBLEM	RECOMMENDATION
A. Main breaker trips when all cooking equipment is operating.	A1 Check amp draw of each power leg while equipment is operating. If amperage of any single leg exceeds capacity of main breaker, check operation of cooking equipment and redistribute load along bus bars as needed. A2 If all equipment is functioning properly and all three power legs exceed main breaker capacity, consult factory for instructions for upgrading electrical system. A3 Disconnect all cooking equipment and reset breaker.
B. Main breaker trips when all equipment is disconnected.	B1 Check all wiring for direct short to ground. B2 Check fire protection equipment for trouble condition. Correct and reset as needed.
C. Branch circuit breaker trips.	C1 Check amp rating on cooking equipment vs. capacity of breaker. C2 Check cooking equipment for operational problem or direct short to ground.
<p>NOTE: Some electrical motors can cause nuisance tripping of circuit breakers equipped with highly sensitive ground fault personnel protection. These breakers may not be appropriate for certain appliances that use electric motors such as convention ovens and electric mixers. If nuisance tripping persists the "ground-fault" breaker may need to be replaced with a standard (non ground-fault) breaker or one equipped with "ground-fault equipment protection" which has a field adjustable sensitivity range. Consult the factory for further information.</p>	
D. Gas supply not working.	D1 Check flexible hoses for proper connection. D2 Open branch shut-off valve at bottom of UDS raceway. D3 Open main gas shut-off valves in each riser. D4 Reset automatic gas valve controlled by fire protection system. D5 Check all service valves at main building regulator. D6 Bleed all air from gas piping. D7 Check to see if electrical gas valve is open (check field joint for wiring reconnection of gas valve).

