

AIR BOSS® KES Specifications

AIR BOSS® KES SERIES

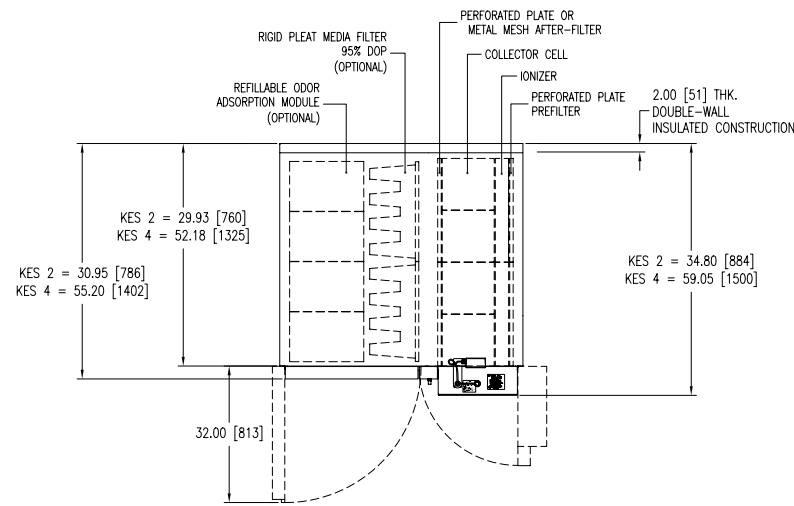

Kitchen Exhaust Filtration System



AIR BOSS® KES SERIES SPECIFICATIONS

INPUT VOLTAGE: 120/220VAC, 50/60HZ
 CURRENT: 1.5 AMP MAX
 OUTPUT VOLTAGE: 12.5 – 13.0 KVDC IONIZER
 6.0 – 6.5 KVDC COLLECTOR
 POWER SUPPLY: (1) PMW WITH STATUS LED FOR KES 2
 (2) PMW WITH STATUS LED FOR KES 4
 POWER SUPPLY STATUS LIGHT: LED, 5 AMP MAX
 WEIGHT OF STANDARD UNIT W/ IONIZER, COLLECTOR,
 PRE & AFTER FILTERS: 480 LBS. [218 KG] KES 2
 650 LBS. [296 KG] KES 4

FILTER COUNT & WEIGHTS FOR KES 2:
 (1) PRE FILTERS – PERFORATED PLATE, 2 LBS. [0.9 kg]
 (1) AFTER-FILTER – PERFORATED PLATE OR METAL MESH, 2 LBS. [0.9 kg]
 (1) IONIZER, 5 LBS. [2.3 kg]
 (2) COLLECTOR, 60 LBS. [27.3 kg] TOTAL
 (1) RIGID PLEAT MEDIA 95% DOP (OPTIONAL), 17 LBS. [7.7 kg]
 (8) REFILLABLE ODOR ABSORPTION MODULE (OPTIONAL), 120 LBS. [54.6 kg] TOTAL

FILTER COUNT AND WEIGHTS FOR KES 4:
 (2) PRE FILTERS – PERFORATED PLATE, 4 LBS. [1.8 KG] TOTAL
 (2) AFTER-FILTER – PERFORATED PLATE OR METAL MESH, 4 LBS. [1.8 KG] TOTAL
 (3) IONIZER, 10 LBS. [4.6 KG] TOTAL
 (4) COLLECTORS, 120 LBS. [54.6 KG] TOTAL
 (2) RIGID PLEAT MEDIA 95% DOP (OPTIONAL), 34 LBS. [15.5 KG] TOTAL
 (16) REFILLABLE ODOR ABSORPTION MODULE (OPTIONAL), 240 LBS. [109 KG] TOTAL

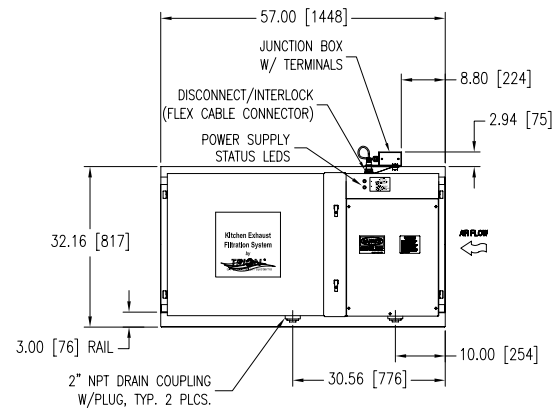
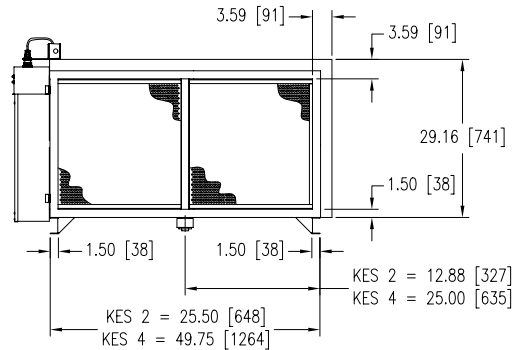

ELECTROSTATIC EFFICIENCY/CAPACITY DATA

	DOP CFM CAPACITIES				
	95%	94%	93%	92%	90%
KES2	1200	1400	1750	2000	2550
KES4	2400	2800	3500	4000	5100
Face Velocity (fpm)	372	434	542	620	790

PRESSURE DROP DATA (Inches H₂O)

	1200	1400	1750	2000	2550
KES2 CFM	1200	1400	1750	2000	2550
KES4 CFM	2400	2800	3500	4000	5100
ESP*	0.09	0.14	0.20	0.27	0.42
Media**	0.13	0.15	0.23	0.25	0.41
Carbon	0.08	0.10	0.15	0.21	0.30
TOTAL**	0.30	0.39	0.58	0.73	1.13

* Includes perforated plate pre- and post filters.
 ** With clean media filters. Allow up to 1" additional pressure drop for filter loading.



FEDDERS ENGINEERED PRODUCTS

Trion Inc.
 101 McNeill Road
 Sanford, NC 27330, USA
 Phone: 800-884-0002
 Fax: 800-458-2379
 www.trioninc.com
 email: sales@trioninc.com

Trion, Ltd.
 The Cavendish Centre
 Winnall Close
 Winchester, Hampshire,
 SO23 0LB, UK
 Phone: +44 (0) 1962 840465
 Fax: +44 (0) 1962 828619
 www.trion.co.uk
 email: info@trion.co.uk

Trion Deutschland GmbH
 Boschstr. 60
 D - 50171 Kerpen
 Phone: +49 (0) 2237 922-103
 Fax: +49 (0) 2237 922-104
 email: info@trion-deutschland.de

Fedders International Air Conditioning
 A-30, Chintels House,
 Kailash Colony
 New Delhi
 India 110048
 Phone: 91 11 5173 0730
 Fax: 91 11 5173 0743
 email: infoindia@fedders.com

Fedders International, Inc.
 128 Joo Seng Road
 #05-01
 DP Computers Building
 Singapore 368 356
 Phone: (65) 6286 0995
 Fax: (65) 6286 0859
 email: infoasia@fedders.com

Fedders International
 No. 728 Fuzhou Road
 Rm. 3002-3005
 Raffles City Office Tower
 Shanghai, P.R. China 200001
 Phone: (86-21) 6340 3232
 Fax: (86-21) 6340 3867/6340 3868
 email: infochina@fedders.com
 Form No. 06-0445
 ©2004 Trion Inc. 7/04





AIR BOSS® KES SERIES, THE RIGHT SOLUTION

g O z ä] z ä ¢ © æ z æ Ú g Ú g Ú Y i Ú Y ä ¢ O © ä ¢ ÷ O Ú z i - O ¢ - i - ä

1. An electrostatic precipitator
2. A 95% DOP media filter
3. Carbon modules for odor control

APPLICATIONS

- Restaurants
- Food Courts
- Hospitals
- Schools
- Sport & Entertainment Complexes

AIR BOSS® KES SERIES CAN HELP YOU ACHIEVE:

© g ¢ æ Ú O Å ä z œ - O] f © O ö Y f ö %



HOW ELECTROSTATIC PRECIPITATORS WORK

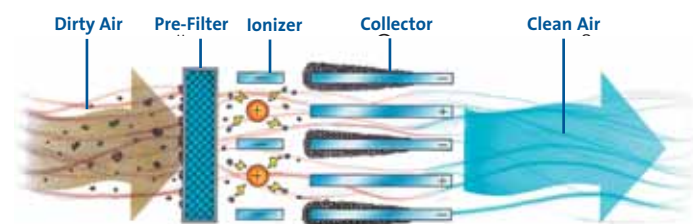

TRION: THE FIRST NAME IN AIR PURIFICATION SYSTEMS

O z æ Ú z q ä Ú ¢ æ Ç z q ä Ú æ ¢ Ú z - O ¢ - i - ä



AIR BOSS® KES SERIES SYSTEM COMPONENTS

